

# The scaling methodology applied for designing HELOKA-US facility, the EU-DEMO HCPB BOP mock-up

S. Perez-Martin, S. Ruck

# EU-DEMO Helium-cooled (HCPB) power plant

- Intermittent heat source: 2 h pulse + ~10 min dwell
- Indirect Coupled Design
  - Thermal Energy Storage System
  - Power Conversion System decoupled from heat source
  - Constant PCS operation and electrical power

■ **Strengths** ➔ Advanced configuration with limited extrapolation with respect to state-of-art technologies

■ **Challenges** ➔ Frequent and fast transitions between pulse and dwell to be handled in normal operation

■ **HELOKA-Upgrade Storage (US) facility** ➔ testing the DEMO HCPB ICD BOP

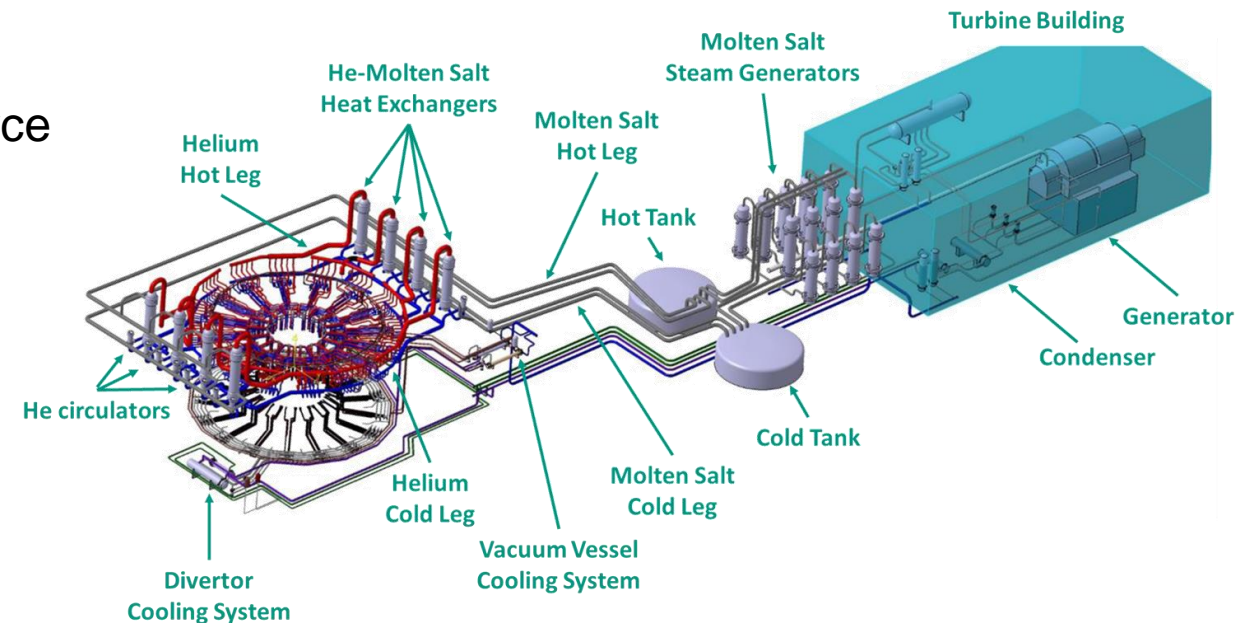

# Outline

- Introduction: framework and goals of the facility
- Scaling methodologies
- HELOKA-US scaling analysis
- Distortions and scaling effects
- Conclusions

# Scaling methodologies for scale-down systems

- Physical design and operating conditions ensuring that relevant **thermal-hydraulic phenomena are preserved** → Data from the loop is applicable to full-size plant
- Hierarchical two-tiered scaling (H2TS):
  1. **Thermal hydraulic phenomena:** Identification and ranking of the important phenomena, processes, and characteristics to be modeled/studied (PIRT).
  2. **Similarity criteria and ranking:** characterizing the thermal-hydraulic phenomenon identified by PIRT
  3. **Scale ratios:** Derive a set of scale ratios from the similarity criteria
  4. **Preliminary design:** Specification the preliminary design of the mock-up.  
Degrees of freedom: working fluid, fluid conditions, geometrical properties (length, diameters), components, material, etc.
  5. **Allowable Distortion:** Evaluation of scaling ratios and distortion (design iteration might be needed).
  6. **Design:** Overall agreement between the design and the similarity criteria

# Hierarchical Two-Tiered Scaling (H2TS)

Scaling issues addressed in two tiers (interaction component-level and local level scaling):

- top-down: balance equations in dimensionless form
- bottom-up: closure relations for characteristic time ratios (models/corr. for specific processes)

Top-down: system scaling analysis
Provide: conservation equations
Derive: scaling groups and charac. time ratios
Establish: scaling hierarchy
Identify: important processes for bottom-up scaling analysis

Bottom-up: Process Scaling Analysis
Perform: Conserv. eqs. and detailed scaling analysis for important local processes
Derive and validate: scaling groups

Adimensional Number	Parametric Definition	Physical representation
Reynolds	$Re = \frac{uD_h}{\nu} = \frac{uD_h\rho}{\mu}$	inertia forces to molecular friction forces (viscous)
Prandtl	$Pr = \frac{\nu}{a} = \frac{c_p\mu}{\lambda}$	ability of a fluid to transfer momentum or heat
Peclet	$Pe = RePr = \frac{uD_h}{a}$	convective to molecular heat transfer
Nusselt	$Nu = \frac{hl}{\lambda}$	convective to conductive heat transfer
Euler	$Eu = \frac{\Delta p}{\rho u^2}$	pressure forces to inertial forces
Grashof	$Gr = \frac{\beta g l^3 \Delta T}{\nu^2}$	lift force and initial force due to density differences to viscous forces
Strouhal	$Sh = \frac{f D_h}{u}$	frequency of vortex shedding and dimension characteristic to flow velocity
Stanton	$St = \frac{h}{\rho c_p u}$	heat transfer rate to the specific enthalpy of the flow
Richardson	$Ri = \frac{\beta g l \Delta T}{u^2} = \frac{Gr}{Re^2}$	buoyancy forces to inertial forces

# H2TS Methodology for HELOKA-US

- Reference System: DEMO HCPB Indirect Coupling design (ICD) Balance of Plant (BOP)
  - Pulsed operating conditions
  - He-cooled PHTS and Molten Salt IHTS coupling
  
- Phenomena Identification and Ranking Table
  - Phenomena in normal operation: forced convection in single-phase flow
  - Processes: plant regulation scheme for charging and discharging (100 s 100% Pn → 1% Pn)
  - Components: He-MS heat exchanger, He compressor

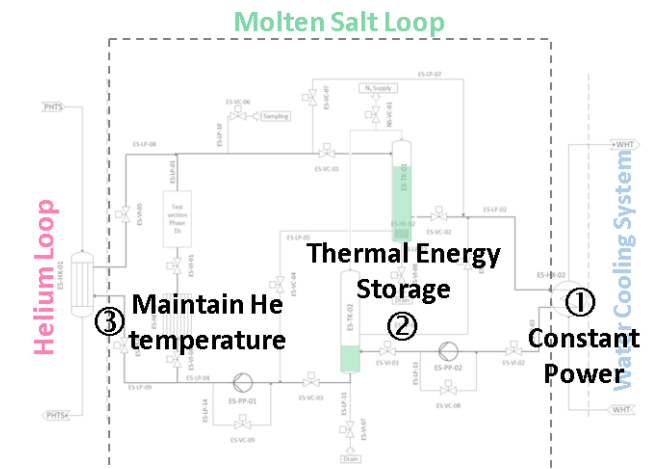
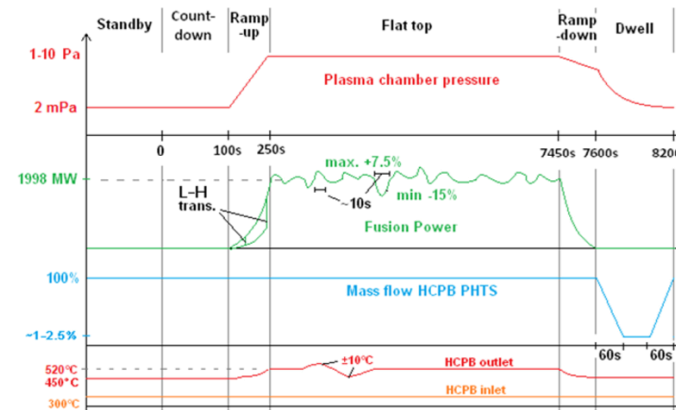
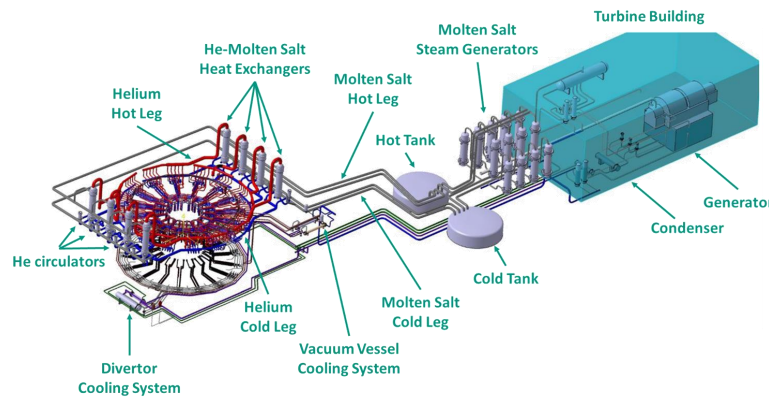

# HELOKA-US Scaling-down ranking

- Level 1: He-DEMO BOP one-to-one.
- Level 2: thermal power
  - Trade-off: TH representativeness and resources (budget & cooling capabilities)
  - Direct impact on all components and systems
- Level 3: component sizing
  - Energy scaling + temperatures → MS flowrate → Piping (pressure drop vs. feasibility, costs).
  - Storage energy is derived → Tank size (standard DN sizes)
- Level 4: as in He-DEMO BOP
- Level 5: component design and selection

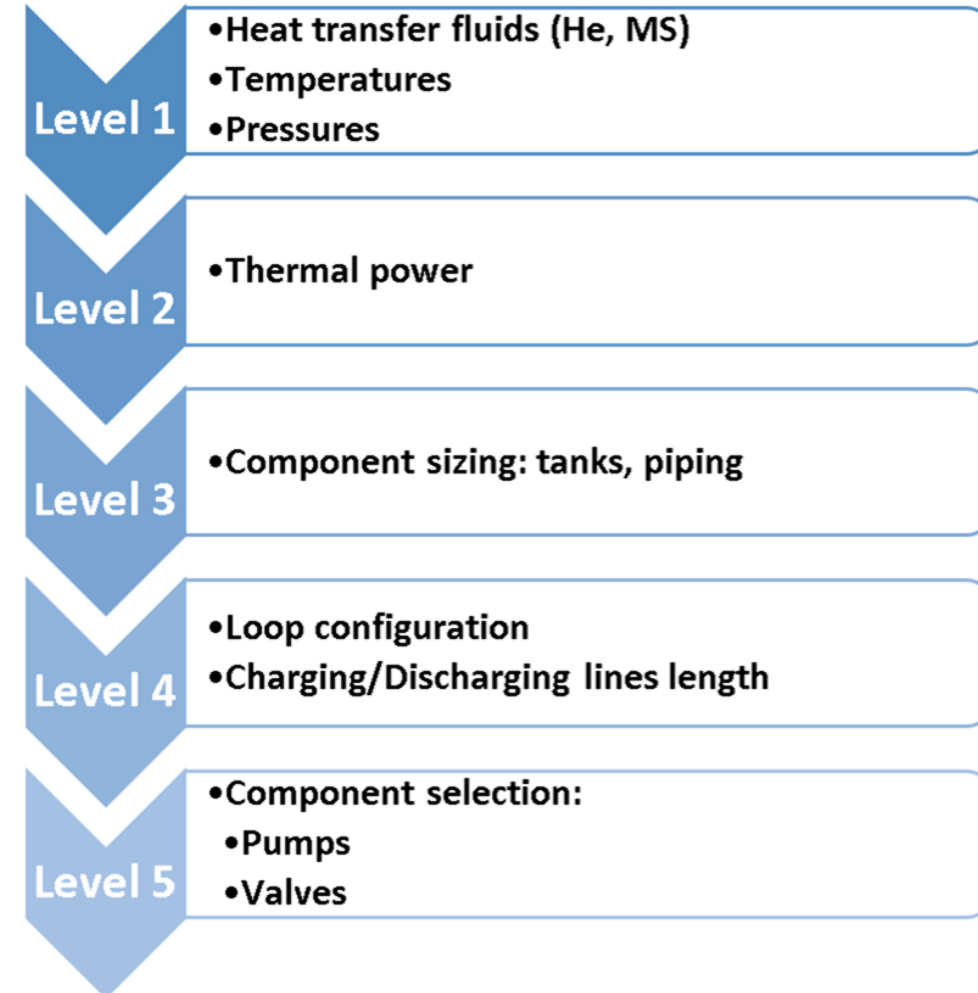

# HELOKA-Upgrade Storage (US) facility

## Design Characteristics:

- 260 kW thermal power
- High pressure Helium loop: 300 - 520°C, 80 bar
- Molten salt loop with two tanks (charging/discharging): 270-465 °C, 6 bar
- Water cooling system: 160 - 220 °C, 45 bar
- Nitrogen cover gas system
- 2 bypasses to control temperature requirements

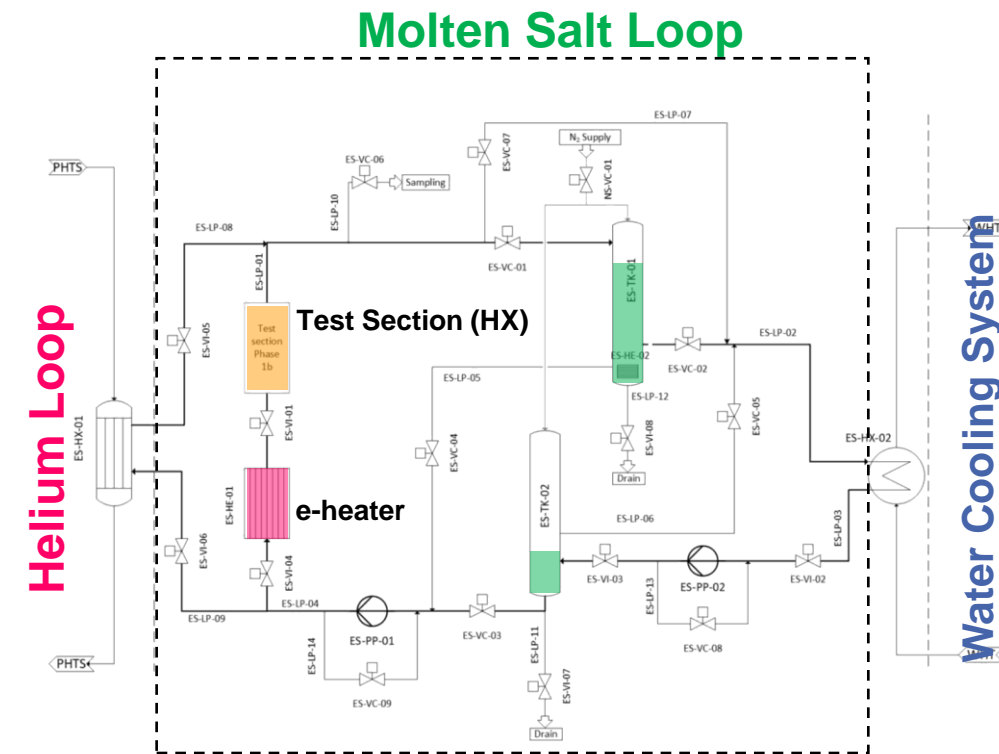

HX: Heat exchanger  
e-heater: electrical heater





# Similarity Criteria: scaling ratios

- Almost all ratios below 10: same orders of magnitude
- Distortion MS tank diameter negligible (tank height for hydrostatic pressure)
- Distortion piping length only in some sections (residence time: length & velocity stays 1-4)

	Ratio DEMO/HELOKA-US
Temperatures (IHX, MS tanks)	1
Pressures (IHX, tanks)	~1
Thermal power	977
Volume	2758
Volume-to-Power	3
Charging - Discharging lines length	7-10
Partial distances (IHX, Tanks, MS SG/HX)	4-12
Hot and Cold Tank diameter/height	54 / 2
MS velocity in cold/hot leg dis/charging line	2-4
Residence time cold/hot leg dis/charging line	1-4

	DEMO	HELOKA-US	Ratio DEMO/HELOKA-US
MS velocity at hot tank inlet (m/s)	1.2	0.43	3
MS velocity at cold tank inlet (m/s)	1.5	0.40	4
MS velocity at IHX inlet (m/s)	1.1	0.43	3
MS velocity at IHX outlet (m/s)	1.2	0.40	3
Residence time cold leg charg. line (s)	275	66	4
Residence time hot leg charg. line (s)	251	63	4
Residence time cold leg disch. line (s)	36	28	1
Residence time hot leg disch. line (s)	75	17	4

# Goals: experimental validation of the decoupling scheme

- ✓ ■ Goal 1: demonstration of MS loop as in DEMO decoupling configuration
  - Steady-states (pulse and dwell)
  - Transitions (P2D and D2P).
  - System Testing & Conditioning, Maintenance, cold and hot stand-by
  
- ✓ ■ Goal 2: experimental data to validate code simulations
  - Flow, temperature, pressure and level sensors to record data
  - Validation of code simulations (APROS, TRACE, RELAP, Dymola, etc.)

# Goals: Experimental Platform to study innovative components, He-MS Heat Exchanger

- Initial reference design: Once-Through Shell and Tube Heat Exchanger with Helium in the tube side and Molten Salt in shell side.

- HELOKA-US Variant B: modular configuration where 6 segments 2.5 m long each are connected in series.

DEMO HCPB ICD BOP  
FP8

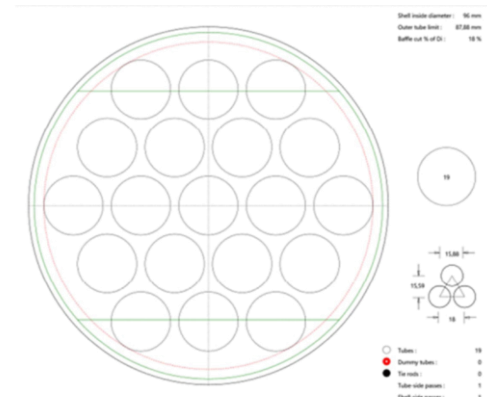
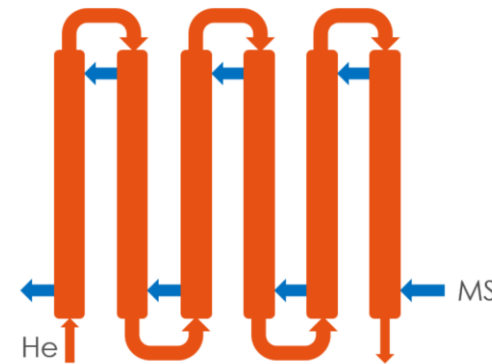
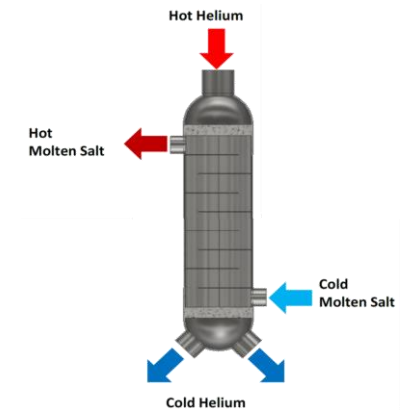
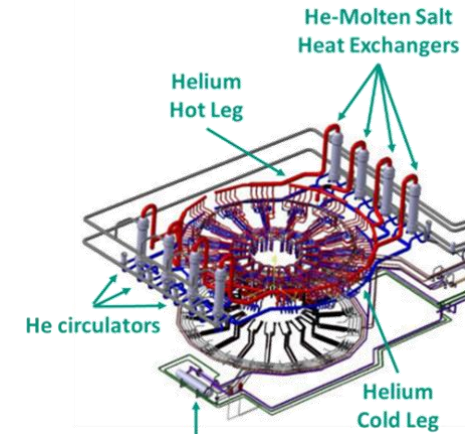

HELOKA-US Variant B

# Goals: Experimental Platform to study innovative components, He-MS Heat Exchanger

	DEMO IHX	HELOKA-US IHX Var. B	Diff. DEMO/H-US Var. B
Thermal Power (MW)	266.729	0.260	1025
Number of tubes	11695	19	616
Tube outer diameter (mm)	15.880	15.880	1.0
Tube length (m)	14.990	14.990	1.0
Shell outer diameter (m)	2.800	0.108	26
He velocity in tubes (m/s)	24.6	22.7	1.1
He Reynolds number	51194	38397	1.3
He tube Pressure Drop (bar)	0.69	0.90	0.8
MS velocity in the shell (m/s)	0.68	0.57	1.2
MS Reynolds number	10037	7445	1.3
MS shell Pressure Drop (bar)	2.10	0.75	2.8
He Nusselt Number	102	81	1.3
MS Nusselt Number	266	79	3.3
Global HTC (W/m <sup>2</sup> C)	1010	542	1.9
Heat Transfer Area (m <sup>2</sup> )	8746	14	615
Euler number (MS side)	247.0	127.3	1.9

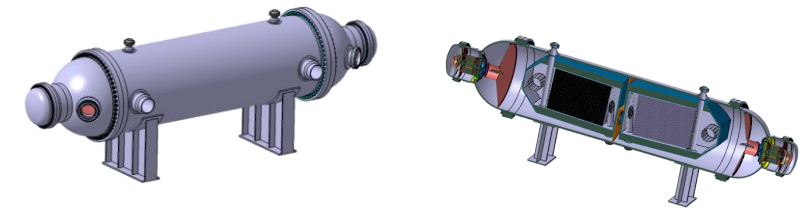
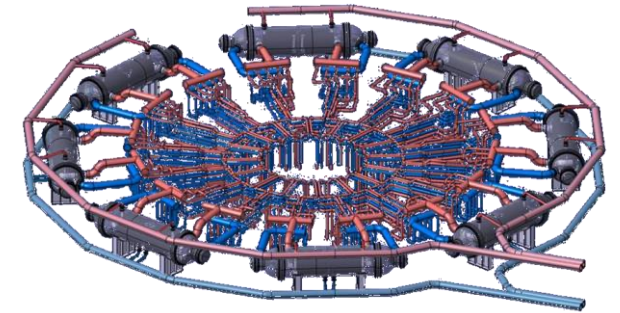

New PHTS and IHX concept

# HELOKA-US R&D Plan

- Phase 1a: commissioning of the MS loop simulating the HCPB IHTS
  - Ph 1a-1 MS loop investigating TH behaviour under DEMO conditions
  - Ph 1a-2 Test section with geometries of interest for the MS side of HXs
  - Ph 1a-3 He-MS HX test section with He supply from HELOKA-HP
  
- Phase 1b: integration of a He-MS HX mock-up operated under steady-states (pulse and dwell) and smooth transients (HELOKA-HP capabilities).

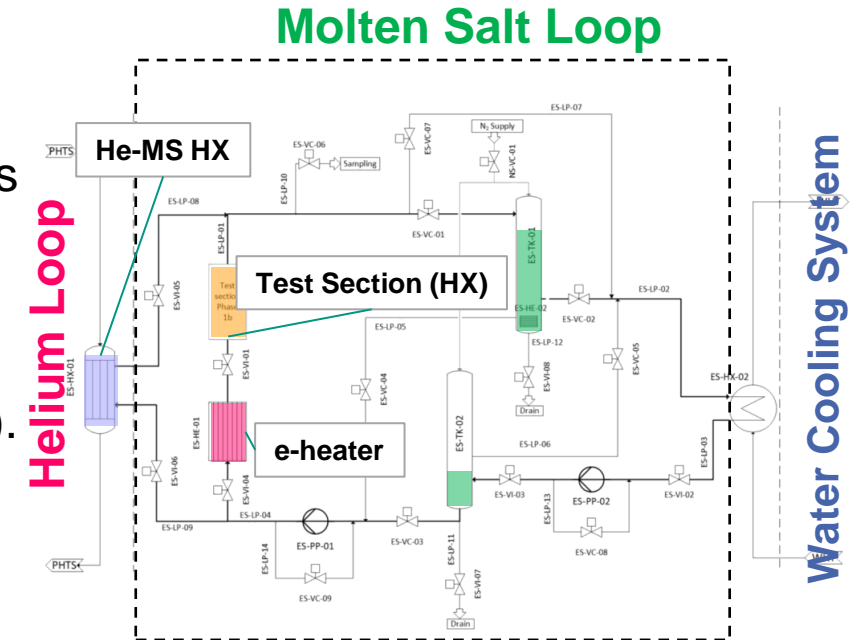

- Exp. results to validate codes used for DEMO assessment
- Exp. feedback to optimize/validate DEMO Plant Control System

	He supply	He-MS interface	MS heat source	Time frame						
				2023	2024	2025	2026	2027		
Phase 1a-1	-	-	Electrical heater	█	█	█	█	█		
Phase 1a-2	-	-	Electrical heater + elect. heated MS side Test Section		█	█	█	█		
Phase 1a-3	HELOKA-HP	He-MS Test Section	Electrical heater + He-MS Test Section		█	█	█	█	█	
Phase 1b	HELOKA-HP	He-MS HX	He-MS HX					█	█	█
Phase 2	New He loop	He-MS HX	He-MS HX					█	█	█

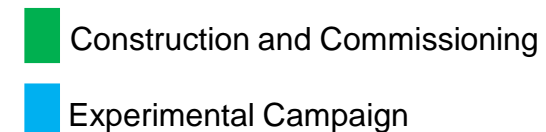

# Conclusions

- HELOKA-US will provide unique contributions to the EU Fusion Roadmap
- Assessment of capability and flexibility of DEMO HCPB ICD BOP concept
- Scaling analysis: top level goals are achieved
- Flexible facility to test innovative components and systems:
  - Experimental data conceived for DEMO HCPB ICD BOP baseline
  - Operational experience for conditioning and maintenance states
  - DEMO BOP Plant control system with the extension by Power-to-X
  - System codes, reduced order models and turbulent HT models in CFD
  - Characterization of MS thermal-physical properties by EOL operation
  - Adaptation to HELIAS (Stellarator) BOP with Power-to-X

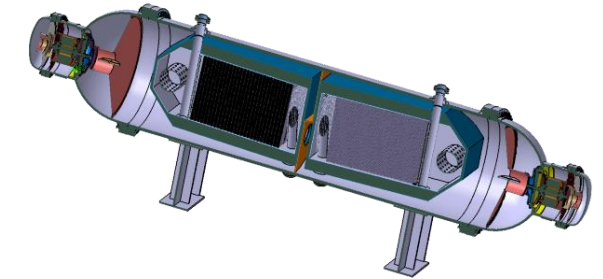

Innovative He-MS HX Designs

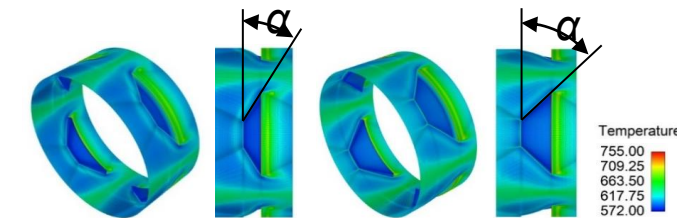

Delta-wing ribs  
HITEC  $Pr = 14.7$   
 $Re = 50.000, 0.3 \text{ MW/m}^2$